



深圳市宇锡科技有限公司

SHENZHEN YOUSEE TECHNOLOG CO., LTD

**DISPLAY SPECIFICATION**

Product NO: (产品型号) YX10149A

Customer : (客户) \_\_\_\_\_

APPROVED BY CUSTOMER 客户签署栏	
Approved by 审核	Remark 备注

APPROVED BY YOUSEE 宇锡签署栏			
Prepared by 制作	Checked by 检查		Approved by 审核
	电子	结构	

深圳市宇锡科技有限公司  
Shenzhen Yousee Technology Co.,Ltd  
邹长城 LONG  
Tel:15818552076  
E-mail: zouchangcheng@youseelcd.com  
Address:深圳市西乡簕竹角鸿竹雍启C栋 5楼 3楼  
3&5 Floor, Building C, Hongzhu Yongqi, Lezhujiiao, Xixiang, Shenzhen



## Table of Contents

Revision History .....	- 3 -
1 General Specifications.....	- 4 -
2 Pin Assignment .....	- 5 -
3 Absolute Maximum Ratings .....	- 6 -
4 Electrical Characteristics .....	- 6 -
5 INTERFACE TIMING.....	- 8 -
5.1 LVDS mode Characteristics.....	- 8 -
5.2 Power ON/OFF Timing .....	- 9 -
6 Optical Characteristics .....	- 10 -
7 Environmental / Reliability Test.....	- 14 -
8 Mechanical Drawing .....	- 15 -
9 Precautions For Use of LCD Modules .....	- 16 -



## Revision History

Rev	Issued Date	Description	Page	Editor
1.0	sept 25.03.25	First release	All	



## 1 General Specifications

Feature		Specifications
<b>Display Spec.</b>	LCD type	10.1 inch
	Resolution (H*V)	1280(RGB)*800
	Technology Type	a-Si TFT
	Pixel Configuration	R.G.B. Vertical Stripe
	Display Mode	Normally Black
	Surface Treatment	Glare
	Viewing Direction	ALL
	Gray Scale Inversion Direction	-
<b>Mechanical Characteristics</b>	OutlineDimensions (W x H x T) (mm)	229.22*149.06*2.6
	Active Area(mm)	216.96*135.6
	With /Without Touch screen	Without
	Match Connector Type	0.5pitch ZIF Connector
	Backlight Type	LED
	Weight (g)	TBD
<b>Electrical Characteristics</b>	Interface	LVDS
	Number of color	16.7M
	CTP Driver IC	/

Note 1: Viewing direction for best image quality is different from TFT definition. There is a 180 degree shift.



## 2 Pin Assignment

PIN NO	SYMBOL	FUNCTION	REMARK
1	NC	NC	
2	VDD	Power supply	
3	VDD	Power supply	
4	VDD	Power supply	
5	NC	NC	
6	GND	GROUND	
7	GND	GROUND	
8	RXIN0-	Data lane0 input	
9	RXIN0+	Data lane0 input	
10	GND	GROUND	
11	RXIN1-	Data lane1 input	
12	RXIN1+	Data lane1 input	
13	GND	GROUND	
14	RXIN2-	Data lane2 input	
15	RXIN2+	Data lane2 input	
16	GND	GROUND	
17	RXCLKN-	CLK input	
18	RXCLKN+	CLK input	
19	GND	GROUND	
20	RXIN3-	Data lane3 input	
21	RXIN3+	Data lane3 input	
22	GND	GROUND	
23-24	NC	NC	
25	GND	GROUND	
26	NC	NC	
27	DIMO	Backlight control (NC)	
28	GND	GROUND	
29	NC	NC	
30	NC	NC	
31-33	LED-	LED Cathode	
34~37	NC	NC	
38-40	LED+	LED Anode	



## 4 Absolute Maximum Ratings

GND=0V, Ta= 25°C

Item	Symbol	Value	Unit
Power supply voltage for logic	V <sub>DD</sub>	0.3~3.6	V
Input voltage	V <sub>in</sub>	V <sub>DD</sub> +0.3	V
Operating temperature	T <sub>opr</sub>	-20 to 70	°C
Storage temperature	T <sub>stg</sub>	-30 to 80	°C

**Note:** Note1: Absolute maximum rating is the limit value beyond which the IC may be broken. They do not assure operations.

Note2: Background color changes slightly depending on ambient temperature. This

Phenomenon is reversible.

Ta≤70°C: 75%RH max

Ta>70°C: absolute humidity must be lower than the humidity of 75%RH at 70°C

Note3: Ta at -30°C will be <48hrs, at 80 °C will be <120hrs

## 5 Electrical Characteristics

### 5.1 Driving TFT LCD Panel

Item	Symbol	Min	Typ	Max	Unit	Remark
Power supply voltage for LCM	VDD	--	3.3		V	
	AVDD	/	/	/	V	
	VGH	/	/	/	V	
	VGL	/	/	/	V	
	VCOM	/	/	/	V	

Note1: Optical performance should be evaluated at Ta=25°C only .If LED is driven by high

### 5.2 Driving Backlight

Ta=25°C

Item	Symbol	Min	Typ	Max	Unit	Remark
Forward Current	I <sub>F</sub>	--	260		mA	
Forward Voltage	V <sub>F</sub>	--	9.6	-	V	
Connection mode		--	3S11P	--		
LED number	/		33		pcs	
LED life time		20000			hours	

Note1: Optical performance should be evaluated at Ta=25°C only .If LED is driven by high current, high ambient temperature & humidity condition. The life time of LED will be reduced. Operating life means brightness goes down to 50% initial brightness. Typical operating life time is estimated data.

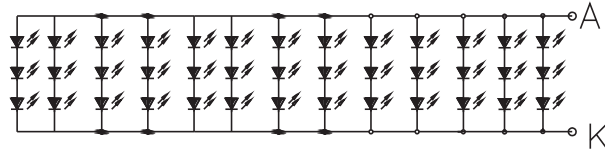

### 5.3 Block Diagram

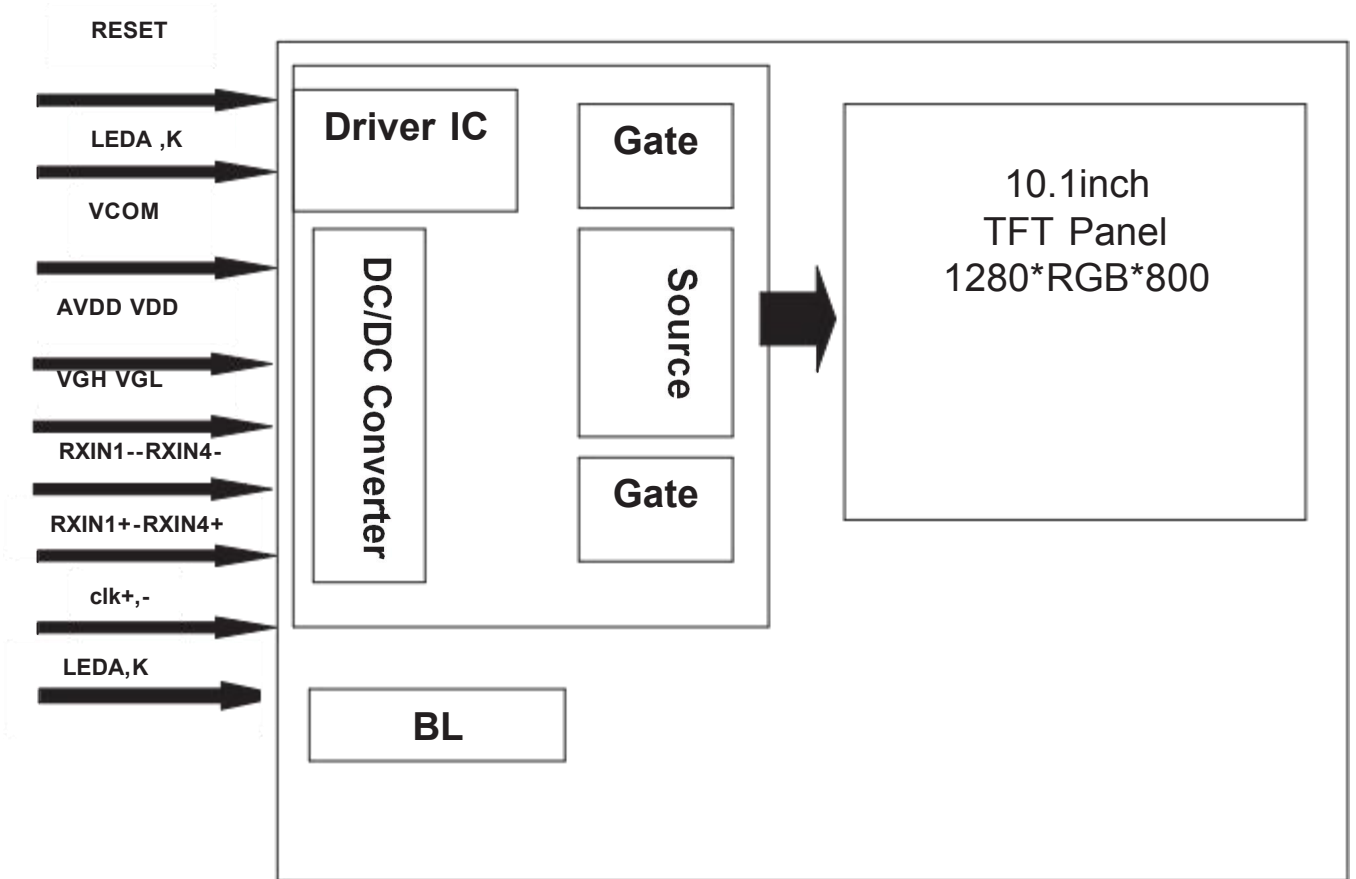

## 6 INTERFACE TIMING

### 5.1 LVDS mode Characteristics.

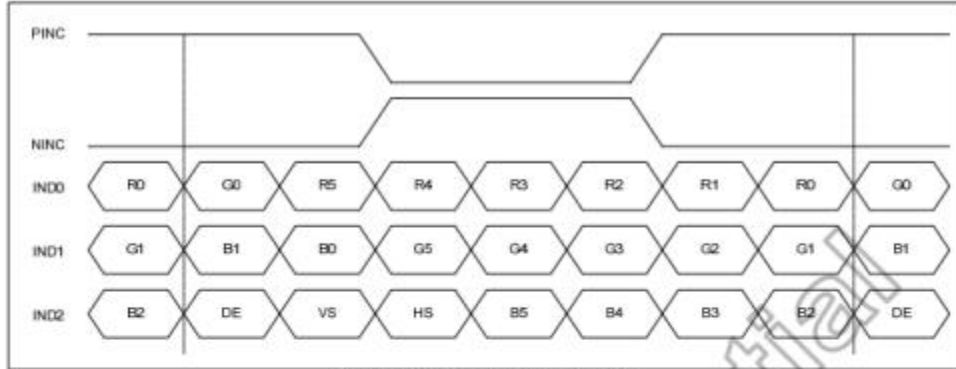

Figure 10.4: 6-bit LVDS input

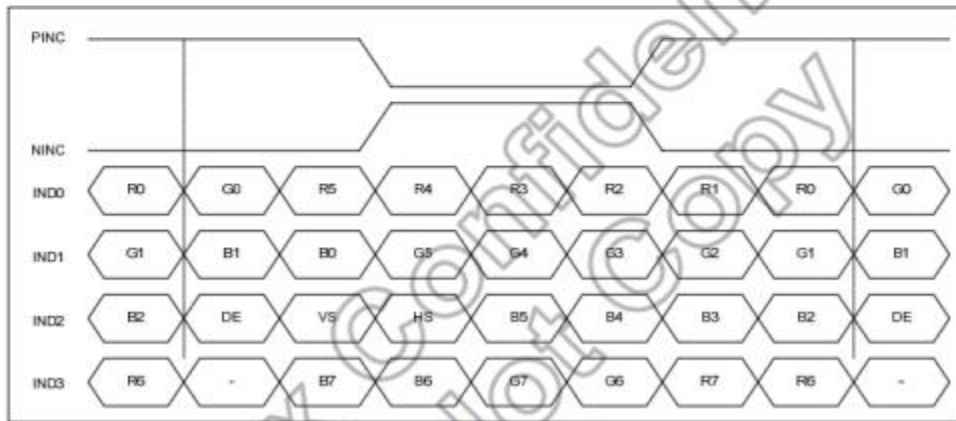

Figure 10.5: 8-bit LVDS Input

#### 5.1.1 LVDS input timing table

Parameter	Symbol	Value			Unit
		Min.	Typ.	Max.	
DCLK Frequency	Fdclk	66.3	72.4	78.9	MHz
Horizontal display area	Thd	1280			pixel
HSYNC period time	Th	1380	1440	1500	pixel
HSYNC blanking	thbp+ thfp	100	160	220	pixel
Vertical display area	Tvd	800			H
Frequency	fV	55	60	65	Hz
VSYNC period time	Tv	824	838	872	H
VSYNC blanking	Tvbp+ Tvfp	24	38	72	H



### 5.2 Power ON/OFF Timing

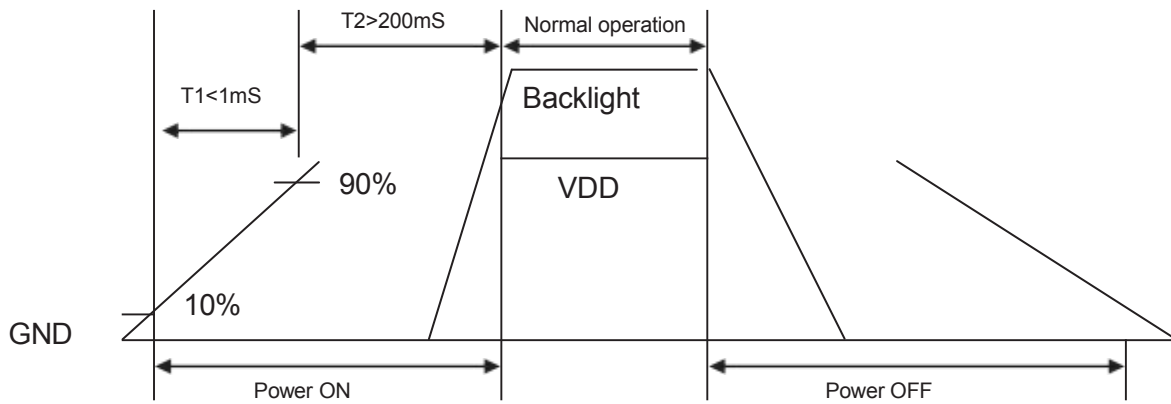

Power ON sequence



Power OFF sequence



## 7 Optical Characteristics

Ta=25°C

Item	Symbol	Condition	Min	Typ	Max	Unit	Remark
View Angles	$\theta_T$	$CR \geq 10$	-	80	-	Degree	Note 2
	$\theta_B$		-	80	-		
	$\theta_L$		-	80	-		
	$\theta_R$		-	80	-		
Contrast Ratio	CR	$\theta=0^\circ$	600	700	-	-	Note1 Note3
Response Time	$T_{ON}$	25°C	-	30	40	ms	Note1 Note4
	$T_{OFF}$		-	30	40		
Uniformity	U	-	70	80	-	%	Note1 Note6
NTSC	-	-	-	70	-	%	Note 5
Luminance	L	-	-	420	-	cd/m <sup>2</sup>	Note1 Note7

Test Conditions:

1.  $V_F=9.6V$ ,  $I_F=330mA$ , the ambient temperature is 25°C.
2. The test systems refer to Note 1 and Note 2.

**Note 1: Definition of optical measurement system.**

The optical characteristics should be measured in dark room. After 5 minutes operation, the optical properties are measured at the center point of the LCD screen. All input terminals LCD panel must be ground when measuring the center area of the panel.

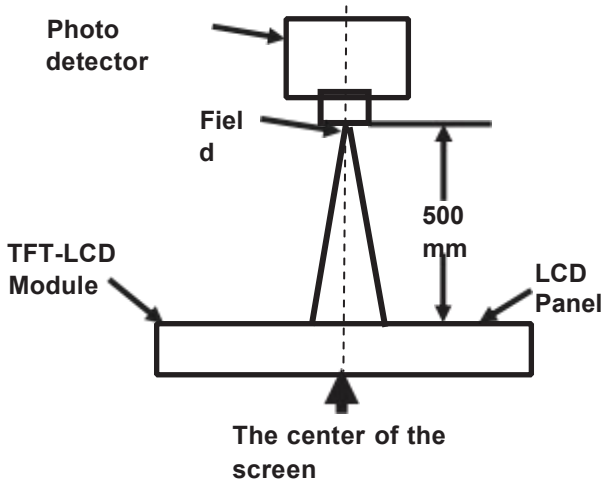

Item	Photo detector	Field
Contrast Ratio	SR-3A	1°
Luminance		
Chromaticity		
Lum Uniformity	BM-7A	2°
Response Time		

**Note 2: Definition of viewing angle range and measurement system.**

viewing angle is measured at the center point of the LCD by CONOSCOPE(ergo-80).

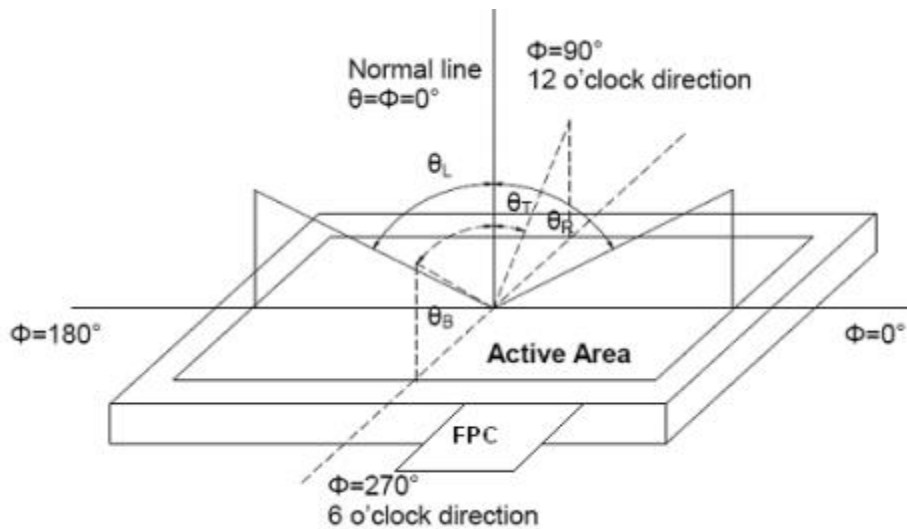

Fig. 1 Definition of viewing angle

**Note 3: Definition of contrast ratio**

$$\text{Contrast ratio (CR)} = \frac{\text{Luminance measured when LCD is on the "White" state}}{\text{Luminance measured when LCD is on the "Black" state}}$$

“White state “:The state is that the LCD should be driven by  $V_{\text{white}}$ .

“Black state”: The state is that the LCD should be driven by  $V_{\text{black}}$ .

$V_{\text{white}}$ : To be determined     $V_{\text{black}}$ : To be determined.

**Note 4: Definition of Response time**

The response time is defined as the LCD optical switching time interval between “White” state and “Black” state. Rise time ( $T_{\text{ON}}$ ) is the time between photo detector output intensity changed from 90% to 10%. And fall time ( $T_{\text{OFF}}$ ) is the time between photo detector output intensity changed from 10% to 90%.

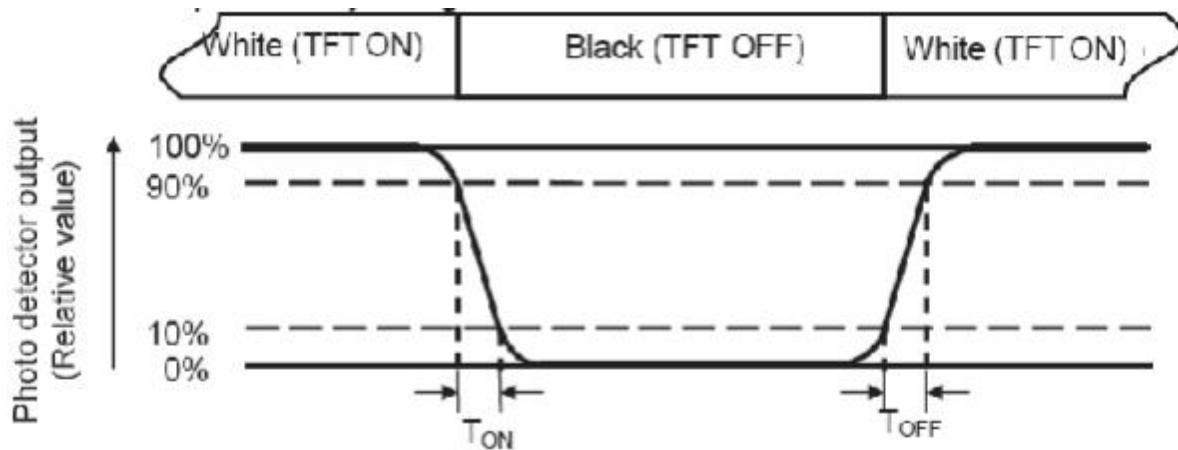
**Note 5: Definition of color chromaticity (CIE1931)**

Color coordinates measured at center point of LCD.

**Note 6: Definition of Luminance Uniformity**

Active area is divided into 9 measuring areas (Refer Fig. 2). Every measuring point is placed at the center of each measuring area.

Luminance Uniformity (U) =  $L_{min} / L_{max}$

L-----Active area length W----- Active area width

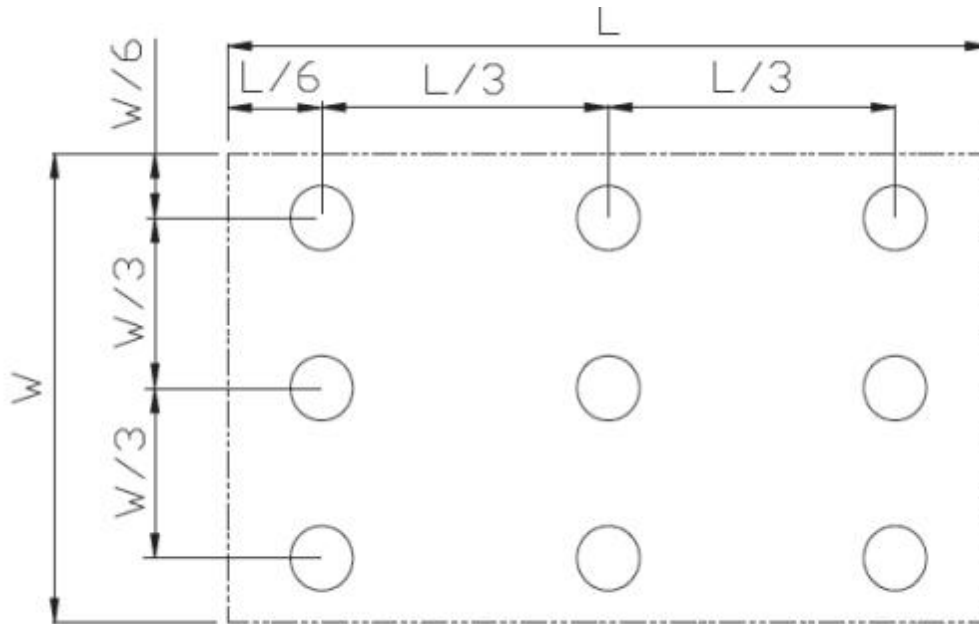

Fig. 2 Definition of uniformity

$L_{max}$ : The measured maximum luminance of all measurement position.

$L_{min}$ : The measured minimum luminance of all measurement position.

**Note 7: Definition of Luminance:**

Measure the luminance of white state at center point.

## 8 Environmental / Reliability Test

Item	Condition	Time (hrs)	Assessment
High temp. Storage	80. C	120	No abnormalities in functions and appearance
High temp. Operating	70. C	120	
Low temp. Storage	-30. C	120	
Low temp. Operating	-20. C	120	
Humidity	40. C/ 90%RH	120	
Thermal Shock(Non-operation)	-20. C ← 25. C → 70. C (0.5 hour ← 5 min → 0.5 hour)	10cycles	

Remark:

1. The test samples should be applied to only one test item.
2. Sample size for each test item is 1~10pcs.
3. In case of malfunction defect caused by ESD damage, if it would be recovered to normal state after resetting, it would be judged as a good part.

8 7 6 5 4 3 2 1

1. 批量产品成品亮度公差为±10%，测试条件IF=20mA/LED, V=3.0V\*3, 3V/LED.
2. 批量产品成品色坐标公差为±0.03.
3. 批量产品均匀性80%以上.

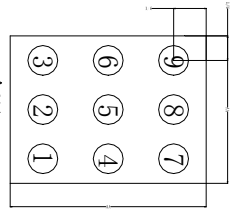

测试距离:500mm  
Measure distance:500mm  
测量角度:1°, 9个点  
Angle: 1°, 9 Points  
亮度值是用BM-7色度仪测试  
The Measurement Instrument is:BM-7  
均匀性=最小/最大亮度值\*100%  
Uniformity=min/ max\*100%

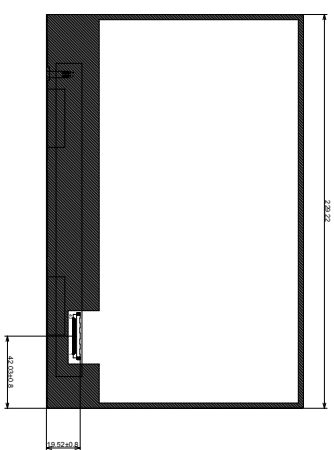
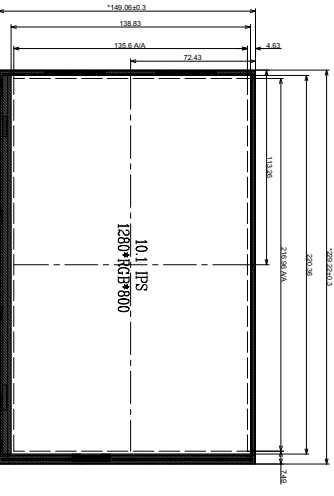

**设计注意事项:**  
1. 图中FRAME VA为推荐TP视窗位置、大小，建议TP视窗位置、大小不要超过FRAME VA。  
2. 整机外壳带泡棉产品，建议客户机壳泡棉进入LCD单边0.5MM MIN, 防止漏光。  
3. 整机外壳不带泡棉产品，建议客户整机TP的丝印黑油开窗或者LENS丝印黑油开窗比LCD A.A区单边大0.6MM MAX。  
4. 客户需保证触摸屏下表面到玻璃上表面最少0.3MM MIN(非贴合)。

**技术要求:**  
1) 液晶显示模式: 10.1" TFT Transmissive  
2) 视角: ALL  
3) 显示颜色: 16.7M COLORS  
4) 驱动芯片型号: /  
5) 工作温度: -20° ~ +70°  
6) 未注尺寸公差: ±0.2mm  
7) 材料及工艺符合 ROHS

01		
00		
版本	更改内容	更改时间



TITLE: ASSEMBLY		DO NOT SCALE THIS DRAWING, GENERAL TOLERANCE: ±0.2	
PART NO.:	YX10149A	MODULE NO.:	00
DRAWN BY:		PROJECTION:	第一角
CHECKED BY:		SCALE: N. T. S	UNIT: mm
APPROVED BY:		SHEET: 1 OF 1	

深圳市宇锡科技有限公司  
SHENZHEN YUXI ELECTRONIC TECHNOLOG CO. LTD

8 7 6 5 4 3 2 1

A

C

D

B

A

C

D

B



## 10 Precautions For Use of LCD Modules

### 10.1 Handling Precautions

- 10.1.1.1 The display panel is made of glass. Do not subject it to a mechanical shock by dropping it from a high place, etc.
- 10.1.1.2 If the display panel is damaged and the liquid crystal substance inside it leaks out, be sure not to get any in your mouth, if the substance comes into contact with your skin or clothes, promptly wash it off using soap and water.
- 10.1.1.3 Do not apply excessive force to the display surface or the adjoining areas since this may cause the color tone to vary.
- 10.1.1.4 The polarizer covering the display surface of the LCD module is soft and easily scratched. Handle this polarizer carefully.
- 10.1.1.5 If the display surface is contaminated, breathe on the surface and gently wipe it with a soft dry cloth. If still not completely clear, moisten cloth with one of the following solvents:
  - Isopropyl alcohol
  - Ethyl alcoholSolvents other than those mentioned above may damage the polarizer. Especially, do not use the following:
  - Water
  - Ketone
  - Aromatic solvents
- 10.1.1.6 Do not attempt to disassemble the LCD Module.
- 10.1.1.7 If the logic circuit power is off, do not apply the input signals.
- 10.1.1.8 To prevent destruction of the elements by static electricity, be careful to maintain an optimum work environment.
- 10.1.1.9 Be sure to ground the body when handling the LCD Modules.
- 10.1.1.10 Tools required for assembly, such as soldering irons, must be properly ground.
- 10.1.1.11 To reduce the amount of static electricity generated, do not conduct assembly and other work under dry conditions.
- 10.1.1.12 The LCD Module is coated with a film to protect the display surface. Be care when peeling off this protective film since static electricity may be generated.
- 10.1.1.13 Storage precautions
- 10.1.1.14 When storing the LCD modules, avoid exposure to direct sunlight or to the light of fluorescent lamps.
- 10.1.1.15 The LCD modules should be stored under the storage temperature range. If the LCD modules will be stored for a long time, the recommend condition is:
- 10.1.1.16 The LCD modules should be stored in the room without acid, alkali and harmful gas.

### 10.2 Transportation Precautions

The LCD modules should be no falling and violent shocking during transportation, and also should avoid excessive press, water, damp and sunshine.